

SPECIFIC EQUIPMENT AND IMPROVED PARAMETERS IN ULTRASONICALLY HYBRID ASSISTED PROCESSES

Cornel-Cristian Enciu¹, Gabriela Parvu (Ene)² and Liviu-Daniel Ghiculescu³
“Politehnica” University of Bucharest, [1cornel.enciu@upb.ro](mailto:cornel.enciu@upb.ro), [2gabriela_marina.ene@upb.ro](mailto:gabriela_marina.ene@upb.ro)
[3daniel.ghiculescu@upb.ro](mailto:daniel.ghiculescu@upb.ro)

ABSTRACT: The paper deals with the main types of installations, tools and equipment used in ultrasonically hybrid assisted processes. The study provides information about the specific components which form an ultrasonic chain such as transducer, reflecting and radiating bushes, concentrator, booster, and integrated tool in terms of materials, shapes, and dimensional characteristics. The output technological performances are also presented which can be improved through hybrid machining processes, using ultrasonic vibrations as: reduction of process forces, higher material rate removal, reduced tool wear, excellent surface quality, higher precision. Some constructive solutions applied to the components of technological systems, which are used at hybrid processes that allow to obtain the improved technological parameters, based on synergetic effect produced by combination of separate processes, are presented.

KEYWORDS: ultrasonic chain, installations, productivity improvement.

1. INTRODUCTION

Nowadays, people work a lot from home, in online and hybrid work schedule, using a lot of micro-components embedded in phones, laptops, or other gadgets. Micro-components are found also in areas like medicine, automotive, aviation, energy, optical fields, where the requirements are very high and the researchers, the engineers work to find new solutions, new technologies to implement in manufacturing.

The application of ultrasonic vibrations on hybrid machining processes can solve a lot of problems and improve the performances of the technologies. The construction of an ultrasonic chain with components like transducer, horn, booster and a generator, can improve the capability of the processes.

This article is divided in two parts, in the first one, the specific installations, tools and equipment are described that can be used in ultrasonically assisted processes. In the second part, some technological performances are enhanced, using ultrasonic vibrations, like the surface quality, the tool wear, the material removal rate, in different situations.

Regarding the material processing, ultrasonic vibrations have two main advantages: lowers the energy consumption and the cost of the process. The effect of ultrasonic energy is like thermal softening at cutting, but the results showed that the ultrasonic energy required to produce an identical amount of softening is 10^7 times less than the required thermal energy. Some researchers used also ultrasonic vibrations for metalworking and concluded that can reduce magnitude of cutting force required to a large

extent [1,17,18]. Hence ultrasonic using is a preferred method of metalworking in our days when the technologies attempt to be very competitive.

2. SPECIFIC INSTALLATIONS, TOOLS AND EQUIPMENT USED IN ULTRASONIC ASSISTED PROCESSES

Ultrasonic systems are installations in which ultrasonic oscillations are produced and transmitted. Currently, a wide range of ultrasound production facilities is used for industrial applications. Depending on the primary energy used, they are divided into two categories [2,3,4]:

a) mechanical installations, when the primary energy used is mechanical energy.

b) electroacoustic installations, in which the primary energy used to produce mechanical vibrations is electricity. Electroacoustic installations are preferred to mechanical ones due to the multiple advantages they have (reliability, increased efficiency, easy maintenance) having, as such, a wider spread.

A typical ultrasonic system has four major components: generator, transducer, horn, and booster. When these elements are integrated, ultrasonic vibrations are transmitted to a desired location, where the tool is located, during a manufacturing process. It is extremely important to have an efficient transfer of ultrasonic power and a factor contributing to that can be the design of the components.

The design and selection of component materials depend upon the intended area of ultrasonic application.

2.1 Energy source

The electronic frequency generator is used as the primary energy source, i.e., the ultrasound generator; it converts industrial frequency of electric current into high frequency current. It is a solid electronic box which is fed in with 220 V and 50 Hz from the mains as inputs and transforms the input into 800-1000 V and 20 or 40 kHz electrical supply, as usual. In the common use, there are two types of generators, conventional and automatic / adaptive, with an example of user interface shown in figure 1.



Figure 1. Ultrasonic generator for 20 kHz output [15]

2.2 Transducer (energy converter)

The ultrasonic energy converter (ultrasonic assembly) has the role of transforming the ultrasonic frequency oscillations into amplified mechanical oscillations at a certain value which are then transmitted to the processing tool or the activating medium. It usually consists of [2,3,4]:

- a) ultrasonic transducer.
- b) ultrasonic concentrator.

The ultrasonic transducer is the element that efficiently converts primary (electrical) energy into acoustic energy. According to the principle of energy transformation, there are several types of transducers, of which the most common are magnetostrictive and piezoelectric.

The **magnetostrictive** effect is manifested in some ferromagnetic materials and consists in the appearance of a mechanical deformation when applying a magnetic field in such a material. The coupling between magnetization and mechanical deformation is a consequence of the domain structure of the ferromagnetic materials and of the generated elastic stresses, when the magnetic vectors are reoriented according to the applied magnetic field. The summing effect of these induced microscopic deformations is a change in body size in the direction of application of the magnetic field. The direction of the deformation is independent of

the direction of the magnetic field, the deformation being proportional to the square of the field.

The **piezoelectric** effect consists in the appearance of electrical charges induced on the surface of a body subjected to mechanical pressures. The size of the electric load is proportional to the applied mechanical stress and the sign changes in relation to the deformation (whether it is expansion or compression). The phenomenon can be reversed: if an electric field is applied to the body with piezoelectric properties, it suffers a mechanical deformation proportional to the applied electric field. The deformation can be expansion or compression according to the sign of the electric field.

In figure 2, is presented the basic structure of a transducer and figure 3, shows a wide variety of transducer shapes used for industrial applications.

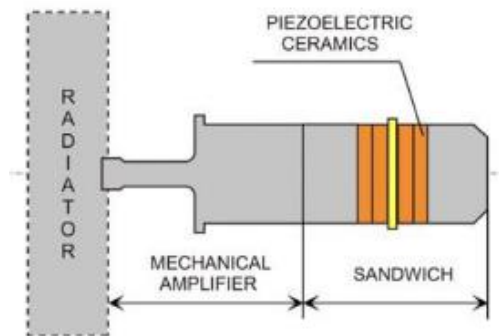

Figure 2. Basic structure of the transducer [1,16]



Figure 3. Different types of transducers [1]

2.3 Ultrasonic concentrator

The ultrasonic concentrator allows the acoustic energy to be concentrated in a smaller volume and to obtain high intensity ultrasonic waves; makes the connection between the transducer and the transfer object to increase the amplitude of oscillation and to ensure an impedance agreement between the transducer and the load in the working space. The concentrator has the shape of a bar with variable cross section and its generator can be conical in shape, cylindrical in steps or can be described by an exponential, catenoidal function, Fourier series (fig. 4), with exterior or interior profiled surface [3].

Resonance condition which consists in equality between own frequencies of transducer and concentrator can be achieved by numerical simulation, and on this basis, CNC machining assures the precise profile of the concentrator [2].

The concentrator is referred by different names like ultrasonic horn, acoustic coupler, tool holder, stub, velocity/mechanical transformer or sonotrode. It is integrated into the ultrasonic setup to enhance the amplitude of ultrasonic vibrations. The material is selected on the basis of the area of its application. In general, steel or titanium are good for high pressure and complex applications, and aluminum for normal applications. The characteristics of the materials used for horn should be good soldering, good acoustic properties, high fatigue resistance at high oscillation amplitude, resistant to corrosion, heat, high wear resistance, high values of toughness and hardness [6,7,8,9,10]. The assembly with the tool can be made in different ways, like soldering, brazing, screw/taper fitting [1].

In figure 4, several basic concentrators are shown, and in figure 5, some customized horns for complex applications can be seen.

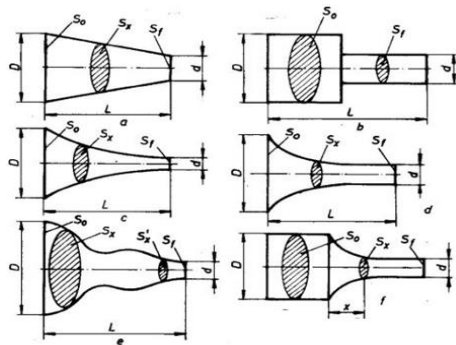

Figure 4. 3D models of exponential and cylindrical concentrators [3]



Figure 5. Customized horns designs used for complex applications [1]

2.4 Booster

A booster is a component of the ultrasonic system, which is used when the amplitude at the end of horn requires some alternation. This element is mounted between the horn and converter and its main function is to amplify amplitude of the resultant

vibration. A smaller diameter of the booster increases the amplitude passing to the horn, and a greater diameter attached to the concentrator decreases the amplitude [1]. In figure 6, are showed boosters of different gain ratios and colour codes.



Figure 6. Boosters of different gain ratios and colour codes [1]

In figure 7, is represented the structure of an ultrasonic chain, where: 1 – reflecting bush; 2 – piezo-electric transducer; 3 – nodal flange; 4 – US horn; 5 – radiant bush; 6 – ultrasonically activated tool / workpiece; 7, 8, 9 – assembling screws.

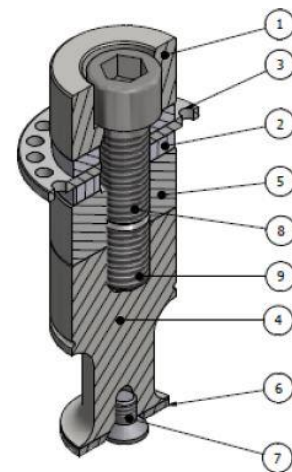

Figure 7. The structure of an ultrasonic chain [3]

In figure 8, it is presented an ultrasonic chain in 3D view. The purpose of this assembly is to investigate the influence of ultrasonic vibration of the electrode-tool in the EDM (electro-discharge machining) process, of a workpiece made of Inconel 718. This is a material used in aviation, space industry, and to obtain a part in a conventional way it is difficult and very expensive due to high hardness and low thermal conductivity [13, 14]. In fig. 9, an US equipment used for microslots machining through ultrasonically aided EDM (EDM+US), comprising a vertical US chain, integrating the blade-shape tool-electrode, and an inclined one, which oscillates

within a hopper supplied with dielectric liquid, used for additional flushing of working gap that is very narrow [19].

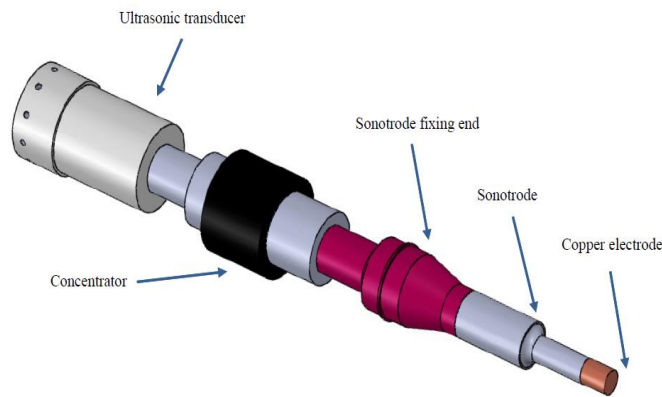

Figure 8. Ultrasonic chain [13]



Figure 9. Ultrasonic chains for EDM+US microslots [19]

In this area of manufacturing, the shape and dimensions of the tools can be varied, depending on the processing performed (figure 10).

It must be borne in mind that there is a point on the axis of oscillation where the vibrations become mechanically destructive, and therefore the point of maximum amplitude must be located in the area of tool location, and the processing is carried out.



Figure 10. Constructive types of tools [3]

At dimensional US machining, using abrasive particles, the material from which the tool is made from must have properties such as [3]:

a. hardness and wear resistance, because after long processing wear occurs by abrasion, which is characterized by unwanted taper and rounding of sharp edges.

- b. ability to transmit energy to abrasive particles.
- c. shock absorption capacity.

Among the materials that can be used to make the tool body, we can list: stainless steel, brass, tool steel, silver steel, tungsten carbide etc.

3. TECHNOLOGICAL PARAMETERS IMPROVEMENT THROUGH HYBRID MACHINING PROCESSES

Using hybrid machining processes can be improved a lot of parameters that affect the life of the parts or of the tools used. In this chapter, are described some of them.

a. Reduction of Process Force

Laser assisted turning, ultrasonic assisted grinding are some examples of assisted hybrid processes which show strong process force reductions. In figure 11, it can be observed an example of major reduction of the drilling torque to quasistatic value, for the vibration assisted deep hole drilling of electrolytic copper ECu57. The value that can be reached independent of feed rate for no load vibration amplitudes (A) is in the range of about 5-10 μm . In the right part of figure 11, can be seen the results of a superimposing oscillation in sheet bulk metal forming. The study showed that with increasing process requirements such as lower die clearance, the superimposed oscillation has a greater effect on the reduction of the forming force and the spring back behavior [5].

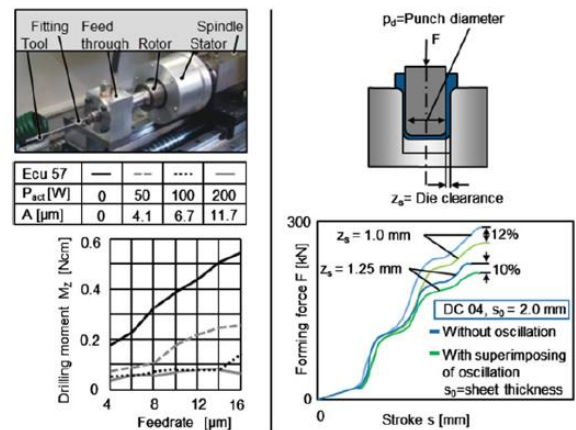

Figure 11. Process force reductions in vibration assisted hole drilling (left) and sheet bulk metal forming (right) [5]

b. Higher Material Rate Removal

The interaction effect between the two energy sources often results in higher material removal rate, and also, the increase of the feed rate. Figure 12 shows the High-Speed EDM Milling (HSEM). In this case, high material removal rates are achieved by promoting controlled electric arcing through use of a non-dielectric medium and a spinning electrode enabling simultaneous multiple discharges and arc to

occur. At the same time, in vibration assisted EDM, an additional relative movement is applied in the system tool electrode, workpiece, and dielectric fluid to increase the flushing efficiency, resulting in a higher material removal rate and better process stability (figure 12, right), [5]. Applying tool or workpiece vibration the tool wear is drastically reduced.

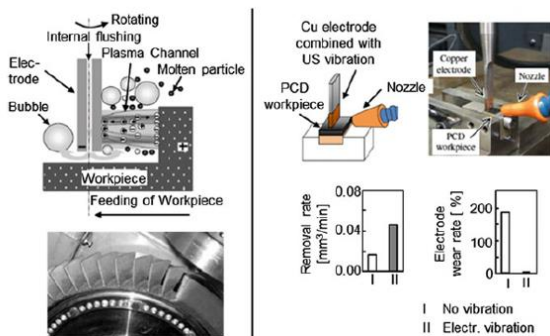

Figure 12. Increase of material removal rate for High-speed EDM (left) and vibration assisted EDM (right) [5]

c. Reduced Tool Wear

Tool wear reductions are observed in vibration assisted EDM and also, in other assisted hybrid processes. In figure 13, are presented the advantageous effect on tool life in cryogenic machining of TiAl6V4 and tool wear behavior in vibration assisted turning. In the second case, the periodic disengagement of the cutting tool during vibration assistance offers the opportunity for ultra-precision machining of hardened steel, glass, and even other ceramic materials with single crystal diamond tools with reduced process forces and increased surface qualities (at least for ferrous materials).

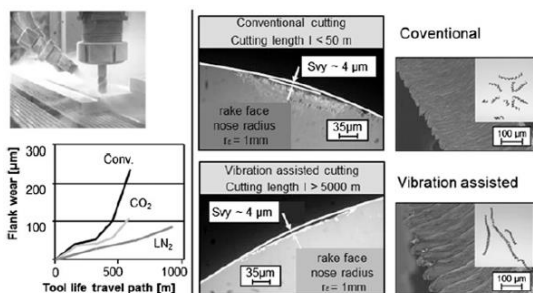

Figure 13. Cryogenic cooling (milling set-up) of TiAl6V4 (left) and tool wear behaviour in vibration assisted turning (right) [5]

d. Excellent Surface Quality

In general, better surface qualities can be obtained with assisted processes. In figure 14, is an example of vibration assisted turning of hardened steel of almost polished surfaces. At the same time, in the right part of the figure is presented a laser assisted machining and can be reported a better quality of the surface. Some advantages are the reducing of the

cutting force and the improvement of tool life. But the effect of vibration is not always positive. Figure 15 presents, ultrasonic assisted grinding, and can be seen that a tool perpendicular to the feed direction can result in surface cracks due to the hammering of the tool [5].

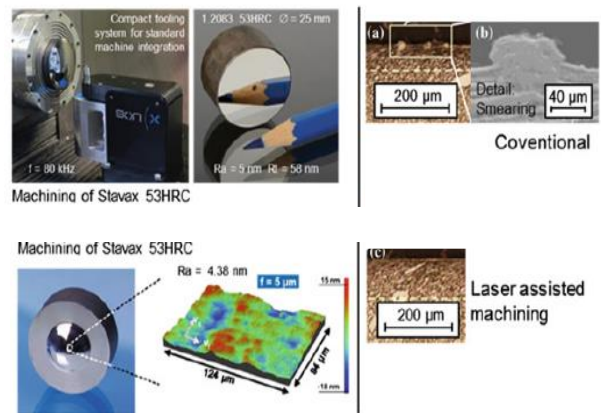

Figure 14. Excellent surface quality in vibration assisted turning (left) and laser assisted machining (right) [5]

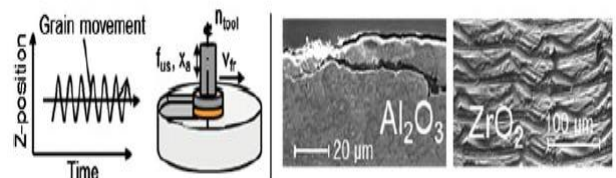

Figure 15. Negative effect of the vibration on the surface quality in rotary ultrasonic assisted [5,11,12]

e. High Precision

A high precision can be obtained in laser assisted single point incremental forming (figure 16). The spring back is reduced, and the formability limits can be extended. In the figure below, are two situations. In the left part is a classical milling machine and in the right part a robot system. For the second case, the sheet metal plate is clamped in a vertical table system. The material is locally heated in front of the moving tool by a laser beam (Nd-YAG laser) acting at the back side of the sheet metal plate, while the shaping tool is moved by a robot [5].

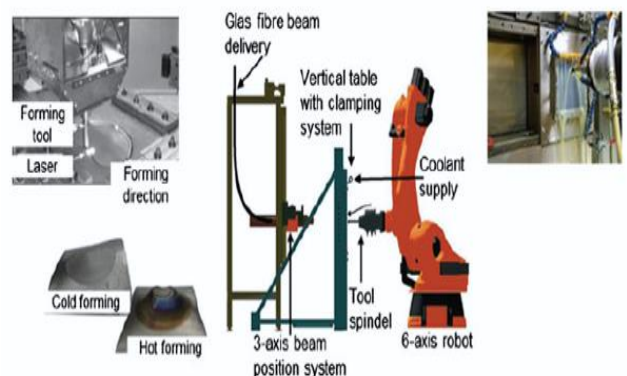

Figure 16. Laser assisted single point incremental forming of sheet metal parts [5]

4. CONCLUSIONS

The structure of an ultrasonic chain contains elements to be optimized in terms of shape, dimensions, and used materials, aiming at improvement of technological parameters like: machining rate, precision, tool wear, and surface quality. The ultrasonic concentrator and the tool are components that can be studied through numerical simulation, validating the results experimentally to obtain better parameters of the parts and to implement new techniques in industry.

There is a growing trend of using ultrasonic vibrations at different conventional or nonconventional processes, with the purpose to improve the main technological parameters at lower costs. A synergy is created by hybridization of classic technologies, where the ultrasonic component, by vibrating the tool or workpiece plays an essential role.

5. ACKNOWLEDGEMENT

This work was supported by a grant of the Ministry of Research, Innovation and Digitization, CNCS/CCCDI – UEFISCDI, project number PN-III-P2-2.2-PED-2019-0367, within PNCDI III.

6. REFERENCES

1. Kumar, S., Wu, C.S., et. al., Application of ultrasonic vibrations in welding and metal processing: A status review, *Journal of Manufacturing Processes* 26, pp. 295-322, (2017).
2. Ghiculescu, D., Ultrasonically Aided Electrical Discharge Machining, in *Electrical Discharge Machining (EDM), Types, Technologies and Applications*, Nova Publishers, New York, USA, (2015).
3. Marinescu, N.I., Ghiculescu, D., Popa, L., Pirnau, C., Marinescu, R., Ene, G.M., *Procese tehnologice cu fascicule, oscilații și jeturi*, Volumul 3, Tehnologii cu unde ultrasonice, ISBN 978-606-23-0984-8, Editura Printech, Cod CNCSIS 54, București, (2019).
4. Ghiculescu, D., *Inginerie și fabricare asistată de calculator în domeniul prelucrărilor neconvenționale*. Îndrumar de laborator, Editura Printech, ISBN 978-606-521-971-7, 149 p., (2013).
5. Brecher, C., *Advances in Production Technology*, Springer, ISBN 978-3-319-12304-2, Germany, (2015).
6. Liu, D., et. al., A cutting force model for rotary ultrasonic machining of brittle materials, *Int J Mach Tools Manuf*, 52:77-84, (2012).
7. Slamani, M., Gauthier, S., Chatelain, J., A study of the combined effects of machining parameters on cutting force components during high speed robotic trimming of CFRPs, *Measurement*, 59:268-83, (2015).
8. Baghlani, V., Mehbudi, P., Akbari, J., Nezhad, E., An optimization technique on ultrasonic and cutting parameters for drilling and deep drilling of nickel-based high-strength Inconel 738LC superalloy, *Int J AdvManuf Tech*, 82:877-88, (2016).
9. Nad, M., Ultrasonic horn design for ultrasonic machining technologies, *Applied and Computational Mechanics* 4, pp. 79-88, (2010).
10. Habiba, L., Lowe, P.S., et. al., Investigation of Ultrasonic Sonotrode Design to Improve the Performance of Ultrasonic Fouling Removal, *IEEE Access*, (2019).
11. Lauwers, B., Surface Integrity in Hybrid Machining Processes, *Procedia Engineering* 19, pp. 241-251, (2011).
12. Lauwers, B., Bleicher, F., et. al., Investigation of the process-material interaction in ultrasonic assisted grinding of ZrO₂ based ceramic materials, *4th CIRP International Conference on High Performance Cutting*, 2:59-64, (2010).
13. Rafal, N., et. al., Influence of Machining Parameters on Surface Texture and Material Removal Rate of Inconel 718 After Electrical Discharge Machining Assisted with Ultrasonic Vibration, *AIP Conference Proceedings*, (2018).
14. Kozak, J., et. al., Development of advanced Abrasive Electrical Discharge Grinding (AEDG) system for machining difficult-to-cut materials, *Procedia CIRP* 42, pp. 872-877, (2016).
15. *** Ultrasonic Generator, Available at: www.aliexpress.com ; Accessed at: 10.10.2021
16. Gallego-Juárez, J., Rodriguez, G., Acosta, V., Power ultrasonic transducers with extensive radiators for industrial processing, *Ultrason Sonochem*, 17:953-64, (2010).
17. Yadav, S., Douranidis, C., Thermomechanical analysis of an ultrasonic rapid manufacturing (URM) system, *J Manuf Process*, 7:153-61, (2005).
18. Daud, Y., Lucas, M., Huang, Z., Modelling the effects of superimposed ultrasonic vibrations on tension and compression tests of aluminium, *J Mater Process Technol*, 186:179-90, (2007).
19. Ghiculescu, D., Marinescu, N.I., Nanu, S., *Equipment for ultrasonically aided electrical discharge machining of microslots*, Patent no. RO-126191 / 30.05.2012.