

BUILDING OF A ROTARY HEAD FOR ULTRASONICALLY AIDED ELECTRICAL DISCHARGE MACHINING

Niculae Marinescu¹, Daniel Ghiculescu², Panagiotis Kyratsis³, Ovidiu Alupei⁴ and Claudiu Pirnau⁵

¹Politehnica University of Bucharest, Romania, niculae.marinescu.upb@gmail.com

²Politehnica University of Bucharest, Romania, daniel.ghiculescu@upb.ro

³Technological Educational Institute of Western Macedonia, Greece, pkyratsis@teiw.m.gr

⁴Politehnica University of Bucharest, Romania, ovidiu.alupei@gmail.com

⁵Politehnica University of Bucharest, Romania, claudiu.pirnau@gmail.com

ABSTRACT: The paper deals with a rotary head for ultrasonically aided electrical discharge machining (EDM+US) that can be used at finishing and semifinishing modes and EDM with complex kinematics - “milling EDM”. The rotary movement of the electrode-tool has the advantage that during the discharge duration, the energy is dissipated over the machined surface, and thus it can be levelled, i.e. the roughness is decreased, but the disadvantage of the instability of EDM process that is increased - often short-circuits between the tool and the workpiece. The ultrasonic vibration of the tool has the capacity to increase the stability of the removal process and hence the output EDM technological parameters. The paper presents the construction of the rotary head in two variants. The first one is more compact and more compatible to be used on CNC machining. The second one has an airier construction, which allows a better cooling of the ultrasonic transducer zone, susceptible to be overheated during EDM process
KEY WORDS: electrical discharge machining, tool rotation, ultrasonic vibration.

1. INTRODUCTION

The actual trend / preoccupation in electrical discharge machining (EDM) of growing the complexity of machined surfaces is substantiated by several technical solutions [1]. These are grouped into major research directions: (a) using complex shaped electrodes with simple tool-electrode path, and (b) using simple shape of tool-electrode with complex kinematics. The present research is framed in case (b).

Electrical Discharge Machining (EDM) with complex trajectory of the electrode-tool, also called “milling EDM”, currently used in CNC machining, has the disadvantage of potential instability of the removal process. This is due to the dynamic change of the working gap since the tool-electrode has a permanent relative movement against machined surface, simultaneously on different axes of coordinates, both translations and rotations. Moreover, the feed and retract movements have to be made on these complex tool paths. This makes more difficult to keep under control the EDM process. It is essential to achieve appropriate evacuation of the particles from the gap as well as avoiding no discharge ignition or short-circuits between the tool and the machined surfaces. However, in case of microEDM drilling, the tool rotation has shown productivity and surface quality increase [2, 3].

The using of ultrasonic vibrations of the electrode-tool was reported, aiming at improving the output

technological parameters associated with tool rotary movement in terms of machining rate (up to 600%) at certain roughness [4]. Rotary tool with up to 200 rpm was used to improve machining rate and surface roughness, using nanoparticles in dielectric liquid [5]. Moreover, other solutions of ultrasonically aided wire electrical discharge machining (WEDM) were reported, applied at wire tool-electrode [6].

2. PHENOMENOLOGY

Due to relative linear speed between the electrodes (anode and cathode, respective the tool and the workpiece, depending on the selected polarity), the two types of electric currents formed within plasma channel, corresponding to the positive ions and electrons, migrating in the electric field from the working gap, will intersect each other only partially, and therefore will interact lesser (fig. 1).

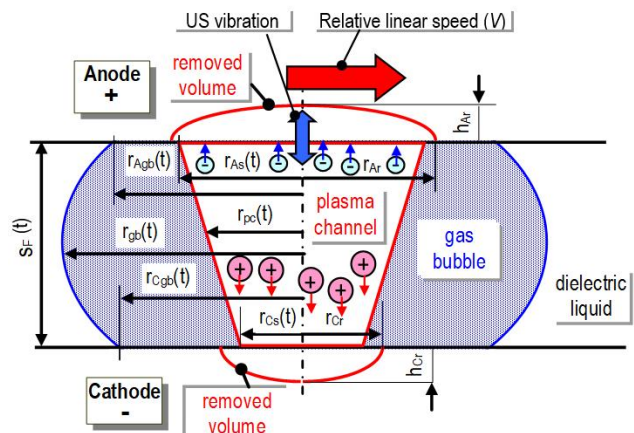

Figure 1. Modelling parameters at rotary tool EDM+US

All the parameters from the fig. 1 are time dependent. The radius of plasma channel, $r_{pc}(t)$, grows progressively when the pulse time increases, generating larger spots on anode and cathode, with radii, $r_{As}(t)$, $r_{Cs}(t)$, and consequently larger radii of generated craters, r_{Ar} , r_{Cr} . The radius $r_{gb}(t)$ of gas bubble formed around plasma channel increases gradually during discharge time, as well as its radii on anode and cathode, $r_{Agb}(t)$, $r_{Cgb}(t)$. The frontal working gap, $s_F(t)$ varies during the removal process, being uneven, depending on the time when anode interact with cathode in terms of number of discharges between them. At the rotation tool around its axis, $s_F(t)$ value is larger in the middle than at the periphery where the relative speed (V) is higher. Thus, electronic bombardment from the cathode is dissipated on larger surface of the anode, $r_{As}(t)$ and the ionic current decreases. So, the density of discharge energy decreases - $r_{Cs}(t)$ is larger, and the craters produced at cathode by discharges have lower depths (h_{Cr}) larger radii (r_{Cr}) and machined surface roughness (Rz) is reduced. Similarly, at anode, the radii $r_{As}(t)$ and r_{Ar} are increased, and the crater depths (h_{Ar}) and roughness Rz is decreased.

When the linear relative speed between the electrodes surfaces decreases, the interaction between those types of currents increases closing to the usual EDM. Although the increase of relative linear speed between the electrodes has a positive effect on finishing EDM process, there is a limit for the relative speed, which once exceeded, the instability of EDM process occurs. Thus, no more material removal takes place from the workpiece, only a material transfer from the tool-electrode to workpiece occurring, copper plating in case of tool from copper is used. V. N. Haldeev reported this phenomenon, working with positive polarity and 1000 - 1500 rpm of workpiece, and 375 - 600 rpm of tool-electrode. The material transfer from the tool to the workpiece was observed to begin at higher relative linear speed than 47.5 m/min. This was more intense at low energy and pulse durations, i.e. $W_e = 10^{-3}-10^{-4}$ J, pulse time $t_i = 3 \mu s$, pulse frequency $f_p = 66$ KHz) [7]. According to Williams and Zolotych, at low pulse durations or first stages of the discharges, the material removal process is mainly produced by electrostatic forces through electronic and ionic currents, and then, at longer pulse time, becoming dominantly thermal.

At ultrasonically aided EDM, the amplitude (A) of the vibratory movement of the tool (fig. 1) or the workpiece, affects the value of frontal gap, $s_F(t)$. The parameter A has few micrometers, enough to produce cavitation in the working gap, and to exceed

the cavitation threshold, which depends on the nature of dielectric liquid, composition and characteristics [8]. The ultrasonically induced cavitation within the working gap has a sort of augmented pumping effect, which contributes to better evacuation of the removed particles from the gap. In addition, the gas bubble around plasma channel has much longer life time than pulse time at usual EDM. At EDM+US, it has much shorter life time, due to bubbles collective implosion, which occurs at each final of the stretching semiperiod of dielectric liquid. Therefore, the dielectric liquid could find the workpiece material in liquid state and remove it in larger amount than at usual EDM, increasing machining rate. Moreover, the material could be removed also in solid state, by shock pressure exerted by cumulative microjets on the peaks of machined microgeometry, which are more sensitive at shearing efforts being prominent. Thus, the machined roughness (Rz) is decreased [1].

3. CONSTRUCTION OF ROTARY HEAD FOR ULTRASONICALLY AIDED EDM

The construction of the rotary head for ultrasonically aided electrical discharge machining (EDM) is based on invention [9], applicable at drilling and complex kinematics EDM. The first variant of the device can be mounted on the working head of any electrical discharge machine, using an elastic bush, compatible also with a CNC machine, having a compact construction (fig. 2).

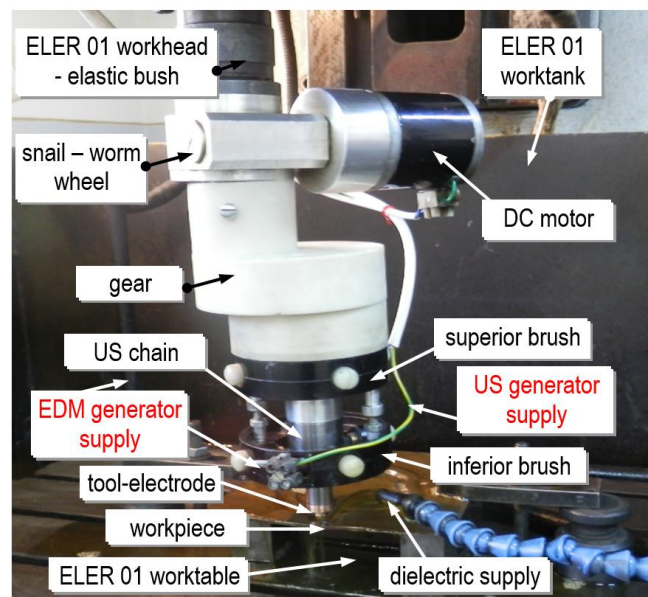

Figure 2. Rotary head for ultrasonically aided EDM – first variant on ELER 01 Romanian machine

The rotary head comprises an ultrasonic chain, which has at its end, the tool-electrode that executes the rotation movement around its axis – fig. 3.

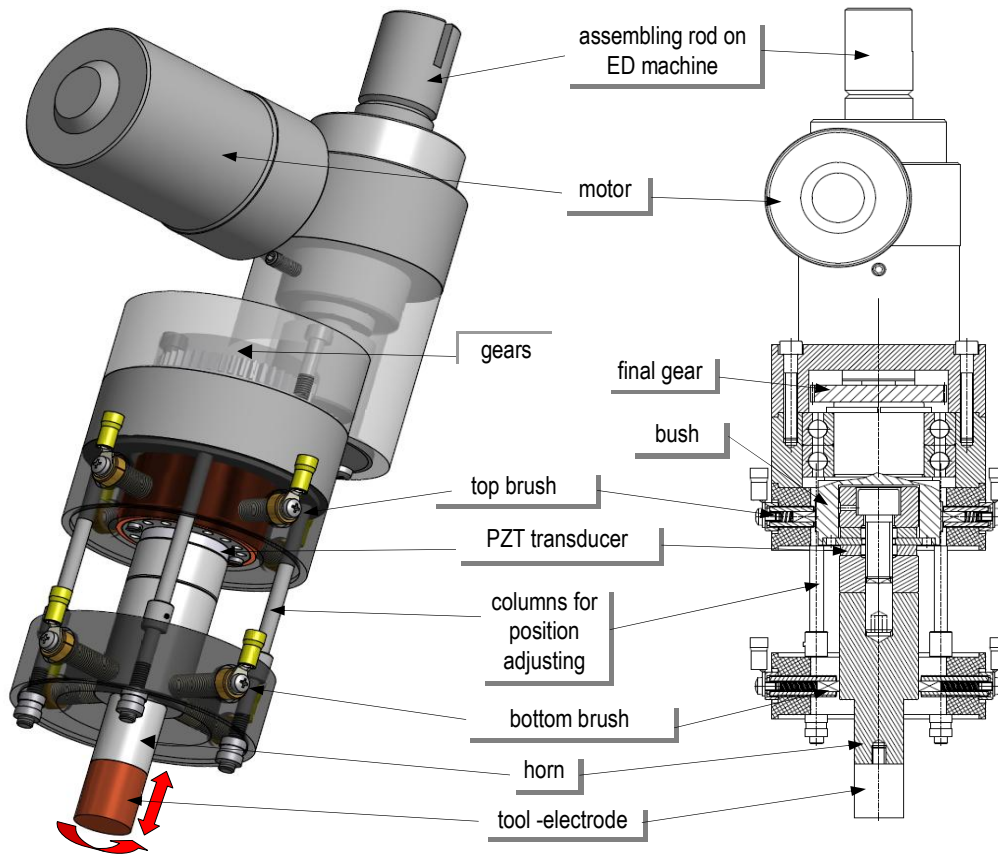

Figure 3. Construction of the rotary head of ultrasonically aided EDM - first variant

In the same time, it executes the longitudinal oscillation movement with ultrasonic frequency. Obviously, it is also involved in EDM removal process by the discharges produced between the tool and the workpiece surface.

The ultrasonic chain is electrically supplied from the ultrasonic generator using two brushes, having four graphite contact elements pressed by springs, positioned in two planes corresponding to the nodal points (null oscillation amplitude). The ultrasonic chain is also supplied from EDM generator at the inferior brush and the null point located on ELER 01 worktable. The inferior brush can be vertically adjusted using two screwed rods and assured by nuts. The superior brush has the four graphite elements in contact with a bush assembled to a nodal flange, which separates the piezoceramic plates of the ultrasonic transducer.

In the first variant of the rotary head construction, the rotation movement transmitted from the motor and snail – worm wheel is taken over by a gear, in which the final toothed wheel is made from electric isolator material, since the tension supplied by ultrasonic generator has around 1000 V. The rotation movement is also assured by a couple of radial- axial bearings – fig. 3.

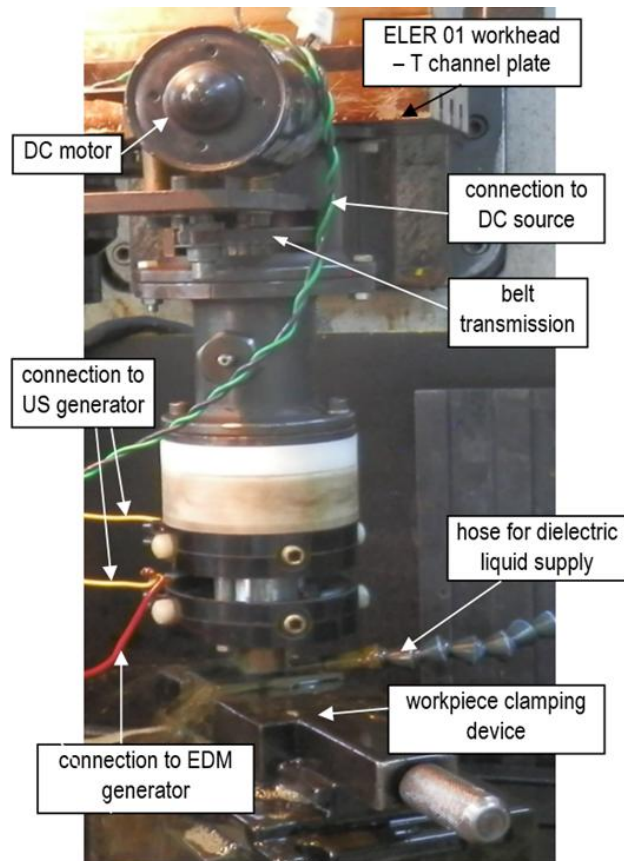

Figure 4. Rotary head for ultrasonically aided EDM – second variant on ELER 01 Romanian machine

The second variant of the rotary head has an airier construction (fig. 4). The rotation movement from a gearmotor is taken over by a belt transmission to the ultrasonic chain, using a profiled coupling made from electrical isolator material. The belt transmission can achieve a greater reduction, aiming at enlarge the possibility of decreasing the linear speed of tool periphery during the EDM removal process. In this case, the construction is simpler, and can be better cooled in the zone of the transducer, susceptible of overheating at long machining time. The rotary head in this variant is easy assembled on the ELER 01 workhead, using T channel plate, and corresponding T head screws.

4. THE ULTRASONIC CHAIN ACHIEVING

For the construction of ultrasonic chain, a transducer provided by the Institute of Solids Mechanics of Romanian Academy was used, having the own frequency of 40.3 kHz. This was the target frequency for obtaining the resonance condition - the equality between the own frequency of the horn that integrates the electrode-tool and that of the transducer.

Before the execution of the ultrasonic chain, a finite element modelling (FEM) of the horn was achieved using Comsol Multiphysics, Solid Mechanics and Eigenfrequency modules. Connection

The parameterization of the model is presented in fig. 5:

Parameters			
Name	Expression	Value	Description
l1	23.53[mm]	0.02353 m	superior length step
r1	17.5[mm]	0.0175 m	superior length radius
l2	24.88[mm]	0.02488 m	inferior step length
r2	10[mm]	0.01 m	inferior step length
modulE	1.532e11	1.532E11	Cu Young's modulus
density	8930	8930	Cu density
rr	r1-r2	0.0075 m	connection radius

Figure 5. Parameterization of finite element model of the horn integrating the tool-electrode

The results of FEM modelling in terms of own frequency and relative deformations are presented in fig. 6. The image shows that a nodal plane / point is located on the ultrasonic horn, more precisely on the larger diameter step (dark blue zone), which was used for the contact with the bottom brush, respectively with the graphite elements pressed by strings.

In the first stage, the ultrasonic horn was executed with the dimensions corresponding to a lower frequency than that of the target, 40.3 KHz.

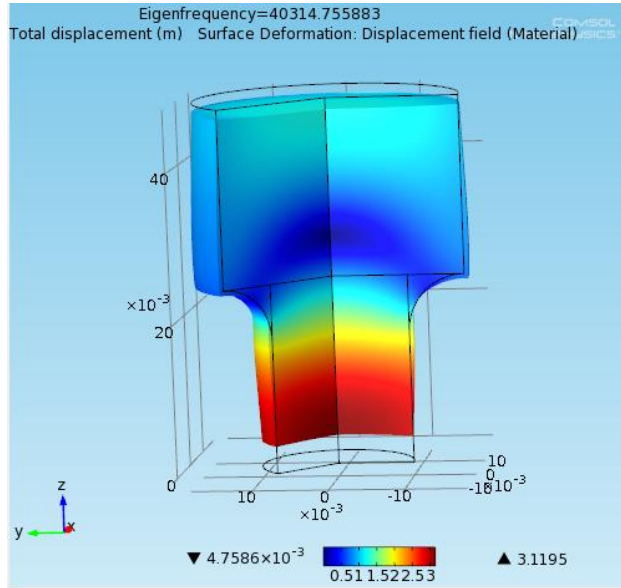

Figure 6. FEM modelling results - own frequency and relative deformation of the horn and the tool at its end

In fig. 7, the experimental stage is presented. A variable tone generator was used to determine the own frequency of ultrasonic horn, in this case, 37790 Hz.

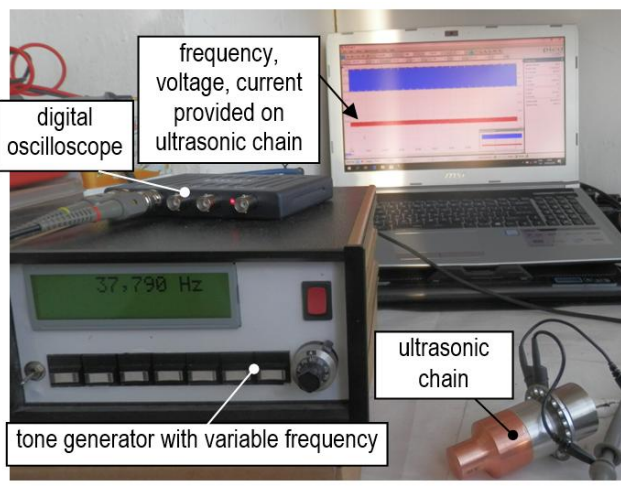

Figure 7. Determination of the own frequency of the ultrasonic chain – first stage

In the next stage, the horn length was decreased from both ends to not modify the positions of nodal and antinodal points, aiming at increasing its own frequency for achieving the resonance condition.

In the final stage, the resonance condition was achieved, verified on the experimental stand presented in fig. 8. The ultrasonic chain was connected also to the ultrasonic generator. The ultrasonic chain was assembled on the rotary head, which was supplied from a DC source with 12 V voltage. It was also checked the ultrasonically induced cavitation – the formation of cavitation bubbles in water – by the ultrasonic chain under conditions of rotational movement.

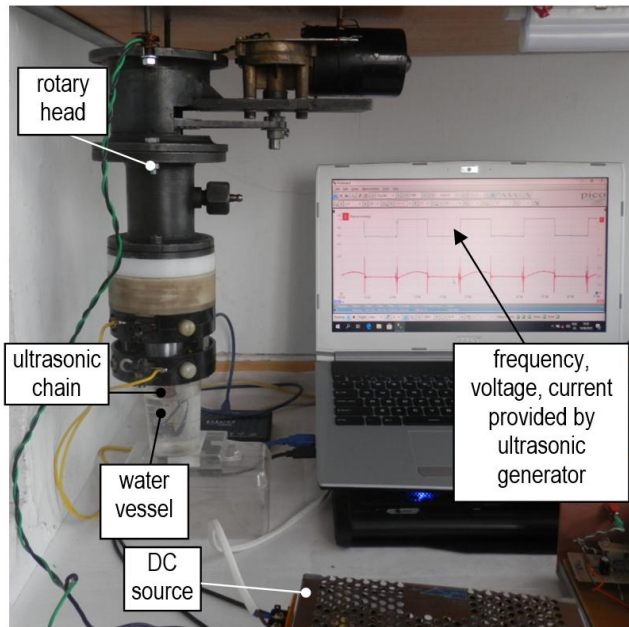

Figure 8. Achieving the resonance condition and ultrasonically induced cavitation on the experimental stand

Thus, the rotary head prototype after fulfilling these preliminary tests, met the conditions to be experimented in the real process of EDM+US, which was the subject of another paper.

7. CONCLUSIONS

The rotary head for ultrasonically aided electrical discharge machining (EDM) has some novelties relative to the state of the art: it can be used at EDM milling (complex 3D kinematics), with the tool-electrode executing simultaneously, rotation and ultrasonic (US) vibration movements; electric supply from EDM and US generators using two brushes in the nodal points: a bottom one in contact with US horn, and a top one connected to the nodal flange, positioned between the PZT disks; the bottom brush is adjustable vertically on columns depending on the nodal point positions; the rotation movement transmitted through gears (or other types of coupling), whose final wheel is electrical isolator and connected to ultrasonic chain through a bushing assembled on the nodal flange.

The advantages of the this rotary head (to be experimentally emphasized in the further researches) are synthesized underneath: high machining rate due to ultrasonic aiding; high stability of EDM removal by improved evacuation of particles from variable working gap between the tool and the workpiece; melted material is removed in very large amount due to ultrasonically induced cavitation in the working gap; high surface quality; short-circuits between the tool and the workpiece are reduced; ultrasonic removal of microgeometry peaks of machined

surface, decreasing the machined surface roughness; using simple tool shapes for generating 3D complex surfaces with obvious advantages of US aiding; easy assembling on ED machine, using available clamping by elastic bushing or T channel plate.

8. ACKNOWLEDGEMENT

Researches financed through the projects: Joint Applied Research Project supported by MEN-UEFISCDI, project no. PN-II-PT-PCCA-2013-4-0236, Contract no. 222/2014.

9. REFERENCES

1. Jahan, M.P., et al. *Electrical Discharge Machining (EDM), Types, Technologies and Applications*, Nova Publishers, New York, USA, (2015).
2. Billa, S., Sundaram, M., Rajurkar K., A study on the high aspect ratio micro hole drilling using ultrasonic assisted micro- electro discharge machining, *Journal of Materials Engineering and Performance* 17 (2), pp. 210-215, (2008).
3. Yu, Z.Y., Zhang, Y., Li, J., Luan, J., Zhao, F., Guo, D., High aspect ratio micro-hole drilling aided with ultrasonic vibration and planetary movement of electrode by micro-EDM, *CIRP Annals*, Volume 58, Issue 1, pp. 213-216, (2009).
4. Ghoreishi, M., Atkinson, J., A comparative experimental study of machining characteristics in vibratory, rotary and vibro-rotary electro-discharge machining, *Journal of Materials Processing Technology*, 120, pp. 374-384 (2002).
5. Baseri, H., Sadeghian, S., Effects of nanopowder TiO₂-mixed dielectric and rotary tool on EDM, *Int. J. Adv. Manuf. Technol*, 83, pp. 519–528, (2016).
6. Mohammadi, A., Tehrani, A.F., Abdullah, A., Introducing a new technique in wire electrical discharge turning and evaluating ultrasonic vibration on material removal rate, *Procedia CIRP*, 6 pp. 583–588, (2013).
7. Haldeev, V.N., The features of material transfer from the tool-electrode to the workpiece in dimensional EDM process at the relative movement of electrodes, *Electronnaia Obrabotka Materialov*, vol. 26, 4, 1990.
8. Anton, I., *Cavitation*, Vol. I and II, Romanian Academy Publishing House, Bucharest, 1984.
9. Ghiculescu, D., Marinescu, N.I., Alupei – Cojocariu, O.D. Carutasu, L., *Rotary head for ultrasonically aided electrical discharge machining*, OSIM Patent request: A / 00528 / 23.07.2015.