

# THE USE OF SOME PRINCIPLES FROM AXIOMATIC DESIGN IN THE CASE OF AN EQUIPMENT FOR THE STUDY OF ELECTROCHEMICAL MACHINING

Laurențiu Slătineanu<sup>1</sup>, Margareta Coteață<sup>2</sup>, Adelina Hrițuc<sup>3</sup>, Oana Dodun<sup>4</sup>, Gheorghe Nagiț<sup>5</sup>

<sup>1</sup> “Gheorghe Asachi” Technical University of Iași, Romania, slati@tcm.tuiasi.ro

<sup>2</sup> “Gheorghe Asachi” Technical University of Iași, Romania, mcoteata@tcm.tuiasi.ro

<sup>3</sup> “Gheorghe Asachi” Technical University of Iași, Romania, hrituc.adelina3295@yahoo.com

<sup>4</sup> “Gheorghe Asachi” Technical University of Iași, Romania, oanad@tcm.tuiasi.ro

<sup>5</sup> “Gheorghe Asachi” Technical University of Iași, Romania, nagit@tcm.tuiasi.ro

**ABSTRACT:** Electrochemical machining is usually included in the wider group of non-conventional machining methods. This method is based on the material removal from the workpiece as a result of chemical reactions between the electrolyte and the material of the workpiece, under conditions where the tool electrode and the workpiece are immersed in an electrolyte and connected to the poles of a direct current source. Using principles from axiomatic design, specialized equipment was designed. This equipment could be used to experimentally investigate the influence of working gap size on the material removal rate from a test sample made of an electroconductive material. The development of the design matrix led to the observation that, in the proposed version, the condition imposed by the first axiom is not strictly respected. This requires the independence of the functional requirements valid for different components of the equipment, which means that there are possibilities for future improvement of the proposed constructive solution. **KEYWORDS:** electrochemical machining, axiomatic design, working gap, machining equipment, the axiom of independence of functional requirements.

## 1. INTRODUCTION

*Electrochemical erosion* machining involves the removal of material from the workpiece as a result of chemical reactions between the workpiece material and an electrolyte in which the tool electrode and the workpiece were previously immersed, both connected to the poles of a direct current source.

The material of the workpiece must be electroconductive.

Electrochemical machining is part of a wider group of machining methods, which has been assigned the name of *nonconventional machining methods*.

There are electrochemical erosion processes in which a higher material removal rate from the workpiece is possible. Still, also there are finishing processes, when the aim is to improve the accuracy and roughness of some surfaces of the part being manufactured.

As a result of the electrochemical erosion process, the products resulting from the chemical reactions may be deposited on the workpiece surfaces, which can reduce the machining speed or even stop the material removal process from the workpiece. To continue machining, it is necessary to ensure conditions for removing the passivation film formed on the machined surfaces of the workpiece as a result of the chemical reactions.

In this way, a classification of electrochemical machining has become possible by considering how the passivation film removal process takes place.

Thus, there are electrochemical erosion machining *processes with the natural removal of the passivation film* (as a result of the agitation of the electrolyte by the hydrogen bubbles appearing at the cathode), *processes with the forced hydrodynamic removal of the passivation film* (processes that use the circulation of the electrolyte in the working gap with high speeds and pressures) and respectively *processes with forced depassivation by abrasion* (based on some hybrid processes, resulting from the association of electrochemical dissolution with an abrasive process, the latter also having the role of determining the removal of the passivating film). Let us note that there is also a group of complex machining resulting by combining the electrochemical dissolution of the workpiece material with the development of electrical discharges, the latter having the role of contributing to the breaking and removal of the passivating film.

For more detailed knowledge of how electrochemical erosion machining is carried out, but also for use in the industrial practice of electrochemical machining, it is necessary to have some information on the so-called working gap, i.e., the space between the tool electrode and the workpiece, at the level of their active areas.

As such, there has been a concern among researchers in electrochemical erosion machining related to the evolution of the distance between the two electrodes during the machining process.

Thus, Kozak addressed problems related to gap evolution when he analyzed thermal models valid for pulse electrochemical machining [1].

Aspects regarding the variation of the size of the working gap during electrochemical machining and the groups of factors able to exert influence on the processes taking place in the working gap are presented in numerous specialized works [2-5].

On the other hand, the last few decades have highlighted the gradual expansion of axiomatic design methodology. This methodology involves the use of axioms in constructive or technological design activities. It was, therefore, normal that in the design activities of some electrochemical machining processes or some equipment for the materialization of some electrochemical machining to try to use some principles from the axiomatic design.

Vargas et al. considered the design of an integrated process for machining titanium components with micro features using principles from axiomatic design [6]. One of the variants of manufacturing airfoils involves the use of electrochemical machining.

Among the machining processes analyzed in Boongsod's design and modeling activities of a miniaturized ultrasonic machining system using axiomatic design principles was electrochemical machining [7].

Chakraborty and Khandekar used fuzzy axiomatic design principles to select a non-traditional machining process [8]. They also considered an electrochemical machining process among the non-conventional machining processes available.

In the present paper, the problem of using some principles of axiomatic design in the case of the need to design equipment for the study of the electrochemical machining process was addressed.

## 2. THEORETICAL CONSIDERATIONS

In principle, in the case of electrochemical machining with natural depassivation, there must be a tool electrode connected to the negative pole of a direct current source and, respectively, the workpiece or test sample connected to the positive pole of the same direct current source. Since the two electrodes are immersed in an electrolyte and if the voltage applied to the two electrodes exceeds a certain value, the chemical reactions between the electrolyte and the material of the workpiece will lead to a gradual

removal of material from the workpiece. This removal of material will occur more intensively in areas where the electric field is stronger or the electric field lines are more frequent, thus providing a higher current density.

The shape of the cavity generated by electrochemical machining is dependent on the shape of the active surface of the tool electrode (fig. 1, *a* and *b*). Even if the shape of the active surface of the tool electrode is flat, the profile of the cavity gradually generated in the workpiece will not reproduce the contour of the profile of the tool electrode, the cavity showing connection radii both at the level of the initial flat surface of the workpiece and in areas further away from the tool electrode.

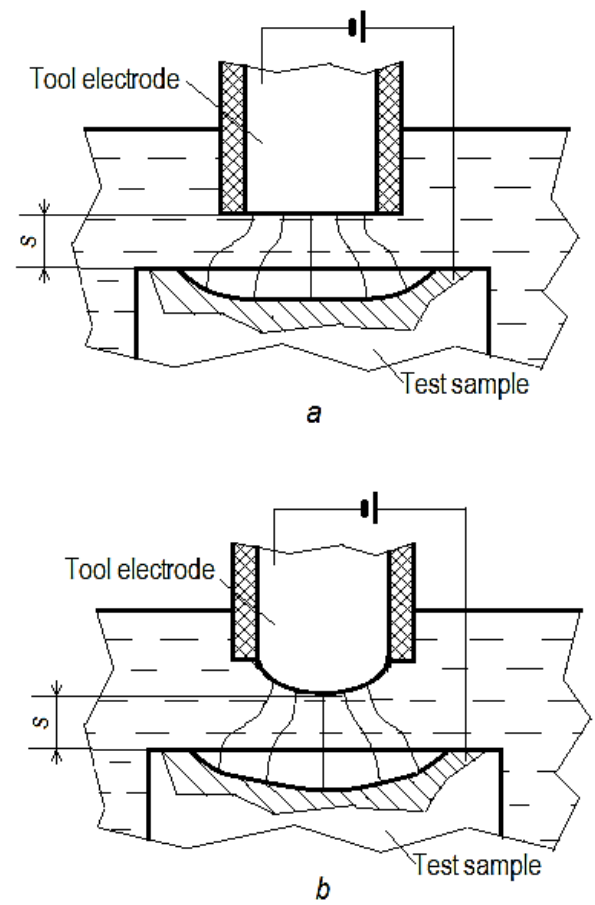

**Figure 1.** The working gap in the case of a tool electrode with a planar active surface (*a*) and respectively with an active surface that has a curvilinear profile in a cross-section (*b*)

The research carried out so far shows that the size of the working gap can be affected by a variation according to the following mathematical relationship [2, 5]:

$$s = \frac{(U - U_{pol} \sigma V_{sp})}{v \sin \alpha} \quad (1)$$

where  $U$  is the voltage applied to the two electrodes,  $U_{pol}$  is the polarization voltage of the electrodes,  $\sigma$  – the electric conductivity,  $V_{sp}$  is the specific volume size of the material removed from the workpiece,  $v$  – speed of the working motion, and  $\alpha$  – the angle between the working direction motion and a tangent to the generated cavity profile in a determined point in the plane of the working direction motion.

Equation (1) allows obtaining information, including the influence that the size of the gap  $s$  exerts on the speed  $v$  of the work movement when such a movement exists. It is thus found that with the increase of the gap  $s$ , the speed  $v$  of the working movement decreases, which leads to a decrease in the rate of material removal from the workpiece, and, at the same time, a decrease in the size of the gap can have the effect of an increase in the risk of producing electrical discharges, with negative effects on the roughness and possibly the accuracy of the machined surface. The size  $s$  of the gap must therefore be established in such a way as to ensure both a sufficiently high removal rate of the material from the workpiece and a low risk of initiating electrical discharges between the two electrodes.

### 3. AXIOMATIC DESIGN

The *axiomatic design* was proposed by the American professor of South Korean origin Nam Pyo Suh towards the end of the 70s of the previous century to be used to optimize the design of technological processes [9].

Contributing effectively to increasing the efficiency of design activities, it has reached the situation that axiomatic design is also used for the constructive design of parts and assemblies of mechanical structures, but also in fields that no longer had direct links with mechanical equipment.

Thus, axiomatic design applications are known in the design of road routes, in the planning of surgical operations, in the planning of sports meetings, etc.

The axiomatic design name takes into account the existence of two axioms, namely:

1. *The axiom of independence*, according to which the FRs functional requirements specific to different components must be independent;
2. *The axiom of information*, according to which, among several alternatives to respond to functional requirements, the alternative that requires the least information or presents the highest probability of successfully solving the addressed problem will be chosen.

### 4. FUNCTIONAL REQUIREMENTS AND DESIGN PARAMETERS IN THE CASE OF EQUIPMENT FOR STUDYING THE ELECTROCHEMICAL MACHINING PROCESS

The problem that will be addressed to succinctly exemplify how to apply some principles from axiomatic design to solve a technical problem will consider the need to make relatively simple equipment, and that will allow highlighting the influence exerted by the size of the working gap  $s$  on the removal rate of workpiece material, in the case of electrochemical machining. Within the framework of axiomatic design, the aforementioned constitute the so-called *customer need CN*. It will be considered that in the present case, the customer is a researcher interested in studying the influence of the size of the gap on some characteristics of interest for electrochemical machining.

Starting from the customer need *CN*, the zero-order functional requirement, *FR0*, can be formulated: design equipment intended to allow highlighting the influence of the size of the working gap on the rate of material removal from the workpiece, in the case of electrochemical machining with natural depassivation and with electrode fixed tool.

Starting from the zero-order functional requirement, the first-order functional requirements *FRs* can be designed through a first breakdown of what is required for the equipment desired by the customer.

These first-order functional requirements could be the following;

- FR1*: Ensure the existence of a source of direct electric current, with possibilities of varying the intensity of the electric current;
- FR2*: Ensure the existence of a test sample that has surfaces at different distances from the active surface of the tool electrode;
- FR3*: Ensure the existence of a subsystem for locating and clamping the test sample;
- FR4*: Ensure the existence of a tool electrode;
- FR5*: Ensure the existence of a tool electrode locating and clamping subsystem;
- FR6*: Ensure the existence of a possibility to feed and position the test sample towards the tool electrode active surface;
- FR7*: Ensure the existence of a possibility to withdraw the subsystem of locating and clamping of the test sample when necessary;

*FR8*: Ensure the existence of a space in which to carry out the electrochemical machining process;

*FR9*: Ensure the presence of an electrolyte;

*FR10*: Ensure the presence of a subsystem for locating and clamping the various components of the equipment, some of these components being immersed in the electrolyte;

*FR11*: Ensure the existence of a possibility of positioning the previously mentioned subsystem to the electrolyte level;

*FR12*: Ensure the existence of a possibility to protect the surfaces of the test sample that must not be affected by the material removal process by electrochemical machining.

The responses to the aforementioned functional requirements are constituted by the so-called *design parameters DPs*.

Identifying acceptable solutions for each functional requirements *FRs* requires a successive movement between the domain of functional requirements *FRs* and the domain of design parameters *DPs*, this action being called *zigzagging*. Design parameters identified in this way could be the following:

*DP1*: Rectifier for charging car batteries;

*DP2*: Test sample with steps that will be at different distances from the active surface of the tool electrode;

*DP3*: Subsystem for test sample locating and clamping;

*DP4*: Tool electrode in the form of a plate, with a flat active surface, made of a metallic material;

*DP5*: Subsystem for tool electrode locating and clamping;

*DP6*: Screw for feeding and positioning of the subsystem for locating and clamping of the test sample to the tool electrode;

*DP7*: Subsystem based on the use of springs;

*DP8*: Container made of a material resistant to the action of the electrolyte. If the container is made of a transparent material and some transparency also characterizes the electrolyte, aspects of the electrochemical machining could be directly observed;

*DP9*: Solution of sodium chloride in water type-electrolyte;

*DP10*: Frame-type piece for supporting some of the subsystems;

*DP11*: Bar-type part that will support the frame-type part and rest on the container;

*DP12*: Material layer resistant to the action of the electrolyte.

The zigzagging activity between the functional requirements *FRs* and the design parameters *DPs* (subsequently the so-called *process variables, PVs* can also be taken into account) can be continued by considering the second-order functional requirements, resulting from the decomposition of the functional requirements of first-order. Sometimes, functional requirements of an even higher order than 2 may arise for detailed design. For these second-order functional requirements *FRs*, second-order design parameters *DPs* will need to be identified.

A representation of the correlations between the 12 functional requirements *FRs* and 12 design parameters *DPs* previously identified can be made by means of a matrix model or a table. The matrix model has the form:

$$\{FR\}=[A] \{DP\}, \quad (2)$$

where  $[A]$  is the design matrix, corresponding to a transfer function between functional requirements *FRs* and design parameters *DPs*.

In the case of the equipment that could be used to study the influence of the distance between the electrodes on the material removal rate by

$$\begin{pmatrix} FR1 \\ FR2 \\ FR3 \\ FR4 \\ FR5 \\ FR6 \\ FR7 \\ FR8 \\ FR9 \\ FR0 \\ FR11 \\ FR12 \end{pmatrix} = \begin{bmatrix} X & 0 & 0 & 0 & 0 & 0 & 0 & 0 & 0 & 0 & 0 & 0 \\ 0 & X & X & 0 & 0 & 0 & 0 & 0 & 0 & 0 & 0 & 0 \\ 0 & X & X & 0 & 0 & 0 & 0 & 0 & 0 & 0 & 0 & 0 \\ 0 & 0 & 0 & X & X & 0 & 0 & 0 & 0 & 0 & 0 & 0 \\ 0 & 0 & 0 & X & X & 0 & 0 & 0 & 0 & 0 & 0 & 0 \\ 0 & 0 & 0 & 0 & 0 & X & 0 & 0 & 0 & X & 0 & 0 \\ 0 & 0 & 0 & 0 & 0 & 0 & X & 0 & 0 & 0 & 0 & 0 \\ 0 & 0 & 0 & 0 & 0 & 0 & 0 & X & 0 & 0 & 0 & 0 \\ 0 & 0 & 0 & 0 & 0 & 0 & 0 & 0 & X & 0 & 0 & 0 \\ 0 & 0 & 0 & 0 & 0 & 0 & 0 & 0 & 0 & X & X & 0 \\ 0 & X & 0 & 0 & 0 & 0 & 0 & X & 0 & 0 & 0 & X \end{bmatrix} \begin{pmatrix} DP1 \\ DP2 \\ DP3 \\ DP4 \\ DP5 \\ DP6 \\ DP7 \\ DP8 \\ DP9 \\ DP10 \\ DP11 \\ DP12 \end{pmatrix} \quad (2)$$

electrochemical machining, such a matrix can be written by considering the 12 functional requirements and respectively the 12 identified design parameters.

For such design conditions, the matrix equation (2) was written. In matrix [A], the functional requirements *FRs* are considered along the lines, while the columns correspond to the design parameters *DPs*.

Analysis of matrix [A] primarily highlights the writing of some *X* symbols along the descending diagonal of the matrix. *X* symbols highlight design parameters that contribute to the fulfillment of a particular functional requirement. When writing matrix [A], the need for each functional requirement *FR* to have at least one design parameter *DP* attached to it was taken into account.

According to the axiomatic design methodology, if the *X* symbols are located only along the descending diagonal, it can be considered that there is a decoupled design judged to be optimal. A triangular matrix is considered acceptable and valid when all *X* symbols are placed above or below the descending diagonal.

In the case of the matrix designed in the first phase of the equipment design, the existence of some situations in which the fulfillment of a functional requirement makes it necessary to apply two or more design parameters is also found, and this fact suggests that there are some possibilities/reserves to improve the design. For example, functional requirement no. 2

(*FR2*, ensuring the presence of a test sample) involves the design parameters *DP2* (the test sample itself) and *DP3* (the subsystem for locating and clamping the test sample). This leads to the inclusion of an *X* symbol above the descending diagonal. Possible elimination of this dependency (so a conformation of the constructive solution to what is required by the first axiom) could consider a design parameter that includes both the test sample and its locating and clamping subsystem. It is noted, moreover, that the design of the subsystem for locating and clamping of the test sample must be strictly correlated with the shape and dimensions of the test sample.

## 5. SOLUTION ADOPTED

The gradual resolution of the problems derived from the use of some principles of axiomatic design in the case of an equipment for the study of the influence exerted by the value of the gap between the tool electrode and the test sample on the material removal during electrochemical machining facilitated the gradual outline of a constructive solution usable in the mentioned meaning (fig. 2). This equipment uses a U-shaped frame, made of plastic material, with a metal bar at the bottom, assembled to the frame by gluing. In a groove in the metal bar, the tool electrode can be immobilized with the help of screws. The part for locating and clamping the tool electrode of metallic material is penetrated by the threaded end of a rod through which the connection of the tool electrode to the negative pole of the direct current source is made. The subsystem for locating and clamping the test

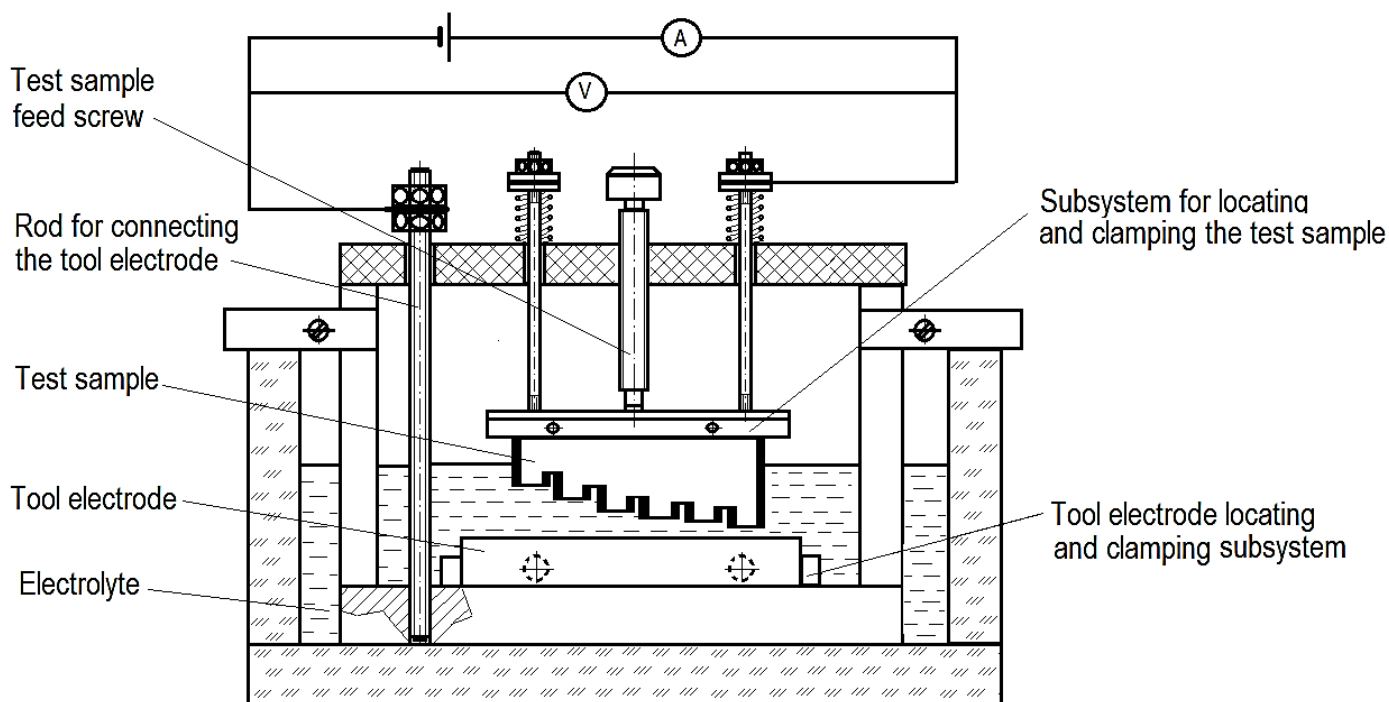

**Figure 2.** Schematic representation of electrochemical machining equipment designed to highlight the influence of gap size on workpiece material removal rate

sample is in the upper part of the frame. This subsystem can be moved towards the tool electrode and positioned with the help of a screw, the test sample being removed under the action of springs. One of the two rods used to guide the test sample locating and clamping subsystem is connected to the positive pole of the direct current source.

It was proposed to use a test sample with steps in the area facing the tool electrode. The side surfaces of the test sample and those between the stepped surfaces will have to be covered with a layer of electrically insulating material that prevents chemical reactions between the test sample material and the electrolyte in areas other than those to be affected by electrochemical machining.

The frame part rests on the walls of a container made of transparent material (glass), where the electrolyte solution (water containing sodium chloride) is located.

Knowing the dimensions of the test sample initially, if the height loss of the stepped areas of the test sample is determined after a predetermined time interval, information can be obtained regarding the material removal rate from the test sample for the conditions of the respective experiment.

## 6. CONCLUSIONS

The consultation of the specialized literature led to the conclusion that there is a particular interest in the study and use of electrochemical machining. On the other hand, the so-called *axiomatic design* can be used in the design of electrochemical machining processes and equipment usable in this direction. Some principles of the application of axiomatic design were used to design a constructive equipment solution that could be used to reveal the influence exerted by the size of the gap between the electrodes on the rate of material removal from the test sample, the latter being an important characteristic of the machining electrochemical. 12 functional requirements were formulated, for which 12 design parameters were identified. The design matrix developed according to the axiomatic design methodology requirements revealed the possibility of improving the constructive solution, which will be given attention in the future. Later, the equipment will be practically materialized, and appropriate experimental research will be carried out with its help for the validation of the constructive solution and

better knowledge of some aspects corresponding to electrochemical machining.

## 7. REFERENCES

1. Kozak, J., Thermal models of pulse electrochemical machining, *Bulletin of the Polish Academy of Sciences. Technical Sciences*, Vol. 52, No. 4, pp. 313-320, (2004)
2. Marinescu, N. I. (editor), Chivu, C., Ghiculescu, D., Herman, R., Ivan, M., Marinescu, N.I., Marinescu, R.D., Măniuț, P., Nanu, A., Nanu, D., Obaciu, G., Pisarciuc, C., Popa, L., Sârbu, F.A., Tițu, M., *Treat of nonconventional technologies. Vol. IV, Electrochemical machining* (in Romanian), Publishing House Printech Bucharest, România, (2006)
3. Nichici, A., Popovici, V., Nica, M., Achimescu, N., Popa, H., Paulescu, G., *Machining by erosion in machine manufacturing* (in Romanian), Publishing House Facla, Timișoara, România, (1983)
4. Nanu, A. *Materials technology* (in Romanian), Didactic and Pedagogical Publishing House, Bucharest, Romania, (1983)
5. Slătineanu, L., Dodun, O., Santo, L., Coteață, M., Munteanu, A., Modelling of the of electrochemical machining process. *IFAC Proceedings*, Vol., 40, No. 18, pp. 475-480, (2007)
6. Vargas, A.V.A., Minhas, S., Lebedynska, Y., Berger, U., *Enhancing productivity through integrated intelligent methodology in automated production environment*. In *Advanced Technologies* (Edited by K. Jayanthakumaran), 2009, available: <https://www.intechopen.com/chapters/8718>, accessed: 24.07.2022
7. Boongsood, W. *Design and modelling of a miniaturised ultrasonic machining system*. Doctoral thesis. United Kingdom, University of Liverpool, (2012)
8. Chakraborty, S., Khandekar, A.V., Application of fuzzy axiomatic design principles for selection of non-traditional machining processes, *The International Journal of Advanced Manufacturing Technology*, Vol. 83, No. 1, pp. 529-543, (2016)
9. Slătineanu, L., *Fundamentals of scientific research* (in Romanian), Publishing House PIM, Iași, România, (2019)